

Shade Structure Type 1

Square Frame. - Flat Top - Sloping Sides to Deflect Wind

INTRODUCTION

This manual for the purchase and building of a 20 foot by 30 foot modular shade structure and is the work of several individuals of the Kostume Kult theme camp. Developed on Google Sketch-up and field tested during early build in 2010; it was assembled and erected in a 45 MPH dust storm.

This structure is self supporting, provides both shade and significant wind protection, and by deflecting the dust upwards, reduces the accumulation of dust inside the covered area.

The original Idea came from experience during 2008, where the flattop canopy, without the side walls, was originally constructed. After the first major wins storm, it was discovered that by using rebar and a 2x4 it was possible to place a wind screen in the middle of a dust storm. That experience led to the design of SST1.

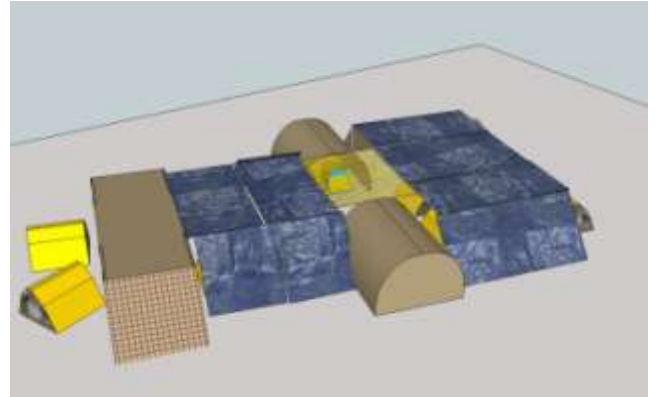

Figure 1: North East View of Intrapod. 2010

Early in the planning process of 2010, the designers collaborated, and discovered that by separate shade structures together, you have a synergy. Placement of side by side shade structures limited mobility. SO, the structures were places 8 – 10 feet apart, allowing for connection with inexpensive 2x4's . Tarps placed between the structures provided extra camping space and a pathway / hang out area between tents.

As the 2010 “Intrapod” developed on Playa, using five distinctly different designs of shade structures, it became evident that connection of spaced shade structures of different design was, in fact, highly effective and easily accomplished.

One Disorient Delta Shade, two Lovemonkey hut's, one PVC 10x20 carport and two steel framed flat tops of various sizes were arranged around a central square flattop. This became the social and hang out area for the 18 campers in the pod.



Figure 2: Intrapod 2010 at night.

Figure 1 shows the wind target for the worst of the storms that year. Bracing against 60 MPH winds, the residents of this pod sat in quiet comfort, watching as other structures crumpled, and the dazed occupants rushed to find shelter within the confines of the Intrapod.

Figure 2 Shows the Intrapod at night. In the photo you can see the protected public space, and how the tents are positioned to be shielded from the wind.

Materials and Supplies

Most if not all of the materials and supplies for building a Shade Structure Type 1 (SST1) are readily available from Tarps.com for the hardware, and your local Home Depot.

Tools: a driving hammer, duct tape and some extra rope are pretty much all that is needed. A flat blade screwdriver may be useful in “snugging down” the thumbscrews which lock tubing not the fittings. Use a little caution. You can easily break off a locking screw or deform the metal tubing so it will be difficult or impossible to disassemble later. Slightly more than “finger tight” will be fine.

The term “fitting” is used to describe the steel frame connectors which are used to hold the tubing in place. “Tubing” refers to the 1 3/8 Fence Rail steel tubing which is used in the design.

Below please find a listing, with photos, of each of the hardware fitting that is required. This manual assumes that two different persons will bring individual shade frames, and they will be joined. If a coordinated effort is being made, or a larger structure constructed, the purchase of the “Five Way” fitting may ease construction, as the connection between frames is built into the design of the fittings.

HARDWARE FITTINGS:

Steel 1 3/8 inch Fence TopRail with Connector fittings From Tarps.com.

Product Name: **1 3/8 Flat 4 Way Center Side**

Item#: F4J

Unit Price: \$6.00

Quantity: 2



Product Name: **1 3/8 Flat 3 Corner**

Item#: P3J

Unit Price: \$5.50

Quantity: 4



Product Name: **1 3/8 Tubing Splicer**

Item#: FCJ

Unit Price: \$3.00

Quantity: 11



Product Name: **9 inch Black Ball Bungees**

Item#: BB9

Unit Price: \$0.27

Quantity: 40



Tarps / Coverings

There are as many opinions regarding “which kind of tarp” to get. Some choose Canvas so it “breaths.” Others go “super cheap,” Assuming they will be throwing away their tarps after the burn.

We believe the most important part of choosing a tarp is the answer to this question “Will you get dark shade?” Most tarps are flimsy affairs which, if you hold up to the sun, you will see sunlight peeking thru the fibers of the tarp. Waterproof does not have a lot to do with SUN proof. The tarps fibers can be thin, and the waterproof coating meager, and it repels “most” rain.

There are two recommendations on tarps, HEAVY and SILVER. The silver helps to reflect some of the heat of the sun, the thicker tarps blocks the filtered sunlight.

You will need five 10 x 20 Tarps for the roofs and front / back down tarps.

You will need two 10x30 tarps for the long sides. (They only have 6 OZ for that size.)

This uses the 1 inch EMT conduit. They are out of 1 3/8 fittings. Trevor must have bought them all!

BE SURE you get 1 inch EMT conduit at home depot. Is Measures 1 inch INSIDE diameter, 1 1/16 outside diameter.

Buy at Home Depot: Pro order means it is pulled and ready for you to pick up. You will need a cargo truck or van to move everything. It would be too heavy for a car roof. Perhaps you can talk to Camp Build leads when they have a truck in Reno. Or you will need to ship on container.

You CAN have home depot deliver to the playa, however it should be coordinated with the camp, because you would be hiring an entire truck, so like, 150 bucks. They can put pallets and pallets of stuff on a truck like that. All of the materials for the entire frontage, showers dance platforms and dj booth were on ONE truck last year.

Item#	Unit Price	Qty	Total	
HD 10x30 6 oz. Poly Tarp	HD1030	\$34.50	2	\$69.00
HDX 10x20 8 oz. Poly Tarp	HDX1020	\$29.00	4	\$116.00
18" Rebar Anchor Stake	RAS18	\$1.50	24	\$36.00
9 inch Black Ball Bungees	BB9	\$0.27	80	\$21.60
1 inch Flat Corner	F3	\$5.00	8	\$40.00
1 inch Flat Roof Center Side L	F4	\$5.50	4	\$22.00
			SubTotal:	\$304.60
			Grand Total:	\$304.60
				PLUS tax and Shipping

HOME DEPOT IN RENO – or NYC on Container.

WHEATLAND 1 INCH EMT	7.42	24	178.08
Model #0550210000 Store SKU # 580015			
2 x 4 x 8 Premium Kiln Dried Whitewood Stud	2.19	12	26.28
			204.36
			PLUS tax and Shipping

Total Cost for Shade for 12 people = PRICELSSS !

But you need about 600 dollars to make it happen.

Assembly

Assuming you get all your supplies out to the Playa, it is very easy to assemble. I will show you in the following drawings how to put up the structure IN THE WIND! Why sit in that stuffy old car when you can don a dust mask and BUILD!

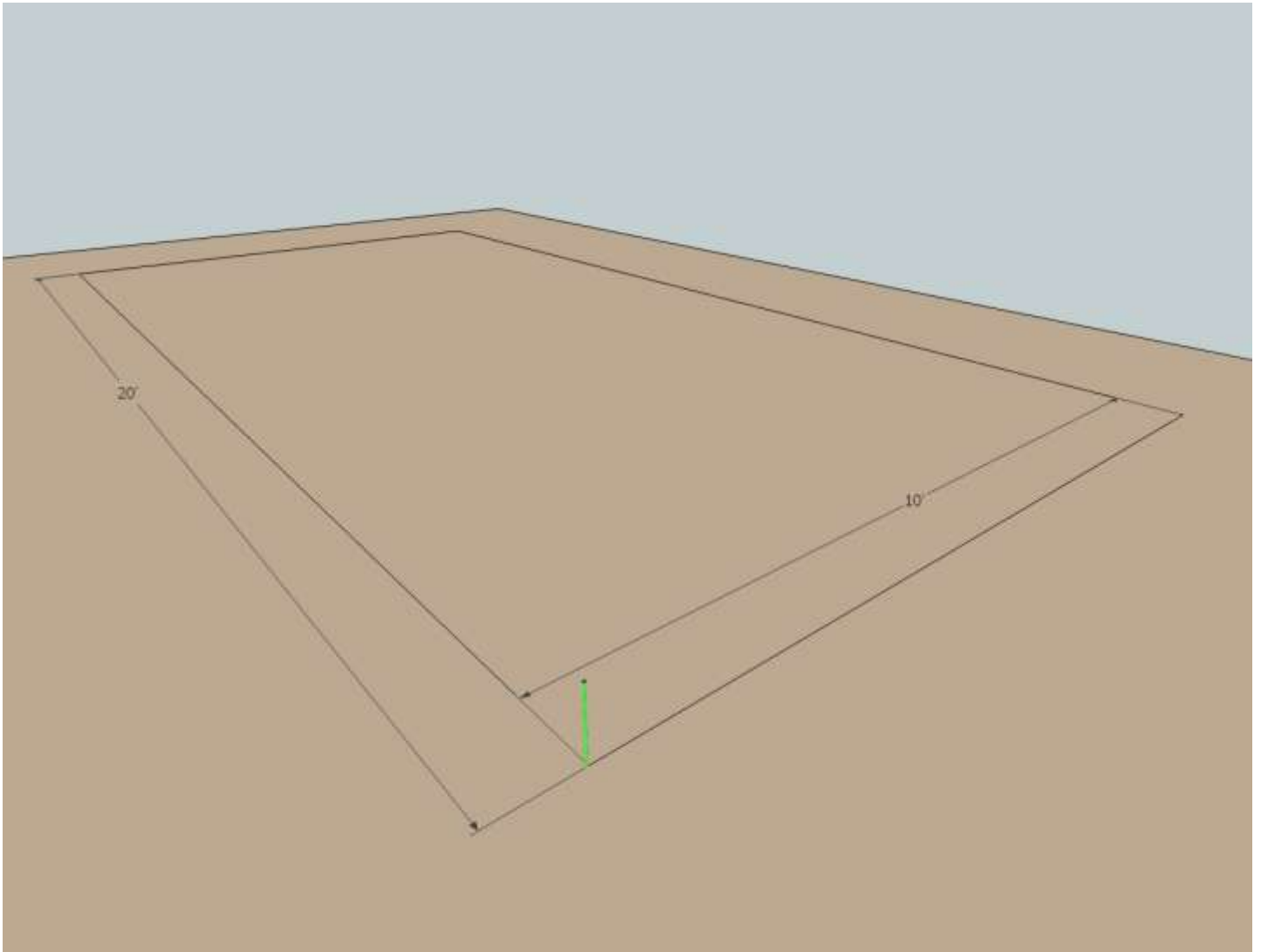

Figure 3: Prepping the Tarp.

In this picture, you see everyone sitting on the tarp just prior to rising. The whiteout is about 3 hours old, and the wind 45 MPH. You can see the frames for the monkey hut in the background, and we will be lifting the blue tarp as a wind break. We were lucky to have the first flat tarp on before the storm.

In the bottom right corner you can see how we secured the poles down. Rebar, Tie Wire and Duck Tape. We also used 300LB test rope to lash it down to the rebar. Solid and no risk of pull out. We joked that if the shade structure was blown away, it would have been the last thing standing on the playa! We also used 300LB test rope to lash it down to the rebar.

Another thing to remember is that there is “no ONE way” to do this. Consider these directions a loving suggestion from folks who have done this before and care about you and your safety.



Measure out your assigned space, or pick an area where you will have protection from the wind. The compass is important. Most of the high winds blow “up” the Playa towards the northeast. Place the corner of your structure so the wind will have a path to flow over the area, and not get caught in the doorway.



Drive your “Golden Spike” and you are ready to begin.

It is a good idea when you are laying out multiple structures to place a corner connector on top of the rebar, so you can see where the shade will be.

As you can see, we had to move all the rebar, tools and whatnot out of the way once we measured where our spot was!

Figure 4: Intrapod Golden Spike!

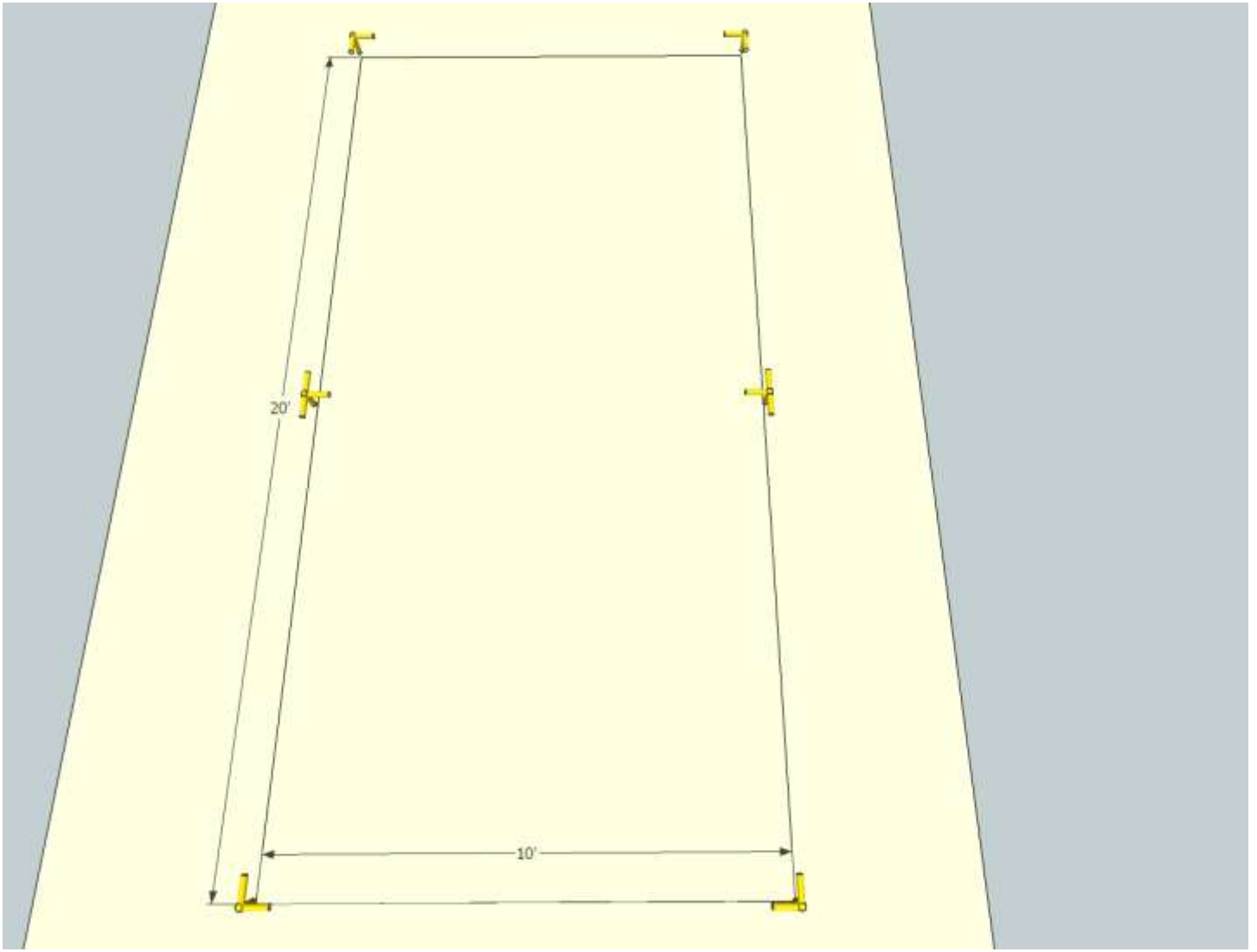

Use your measuring tape to place the other rebar.

Then set the connector for that location as shown. This will simplify things later, as everyone can see where the next tubing goes.

Believe me, in the middle of a dust storm, you need every help you can get.

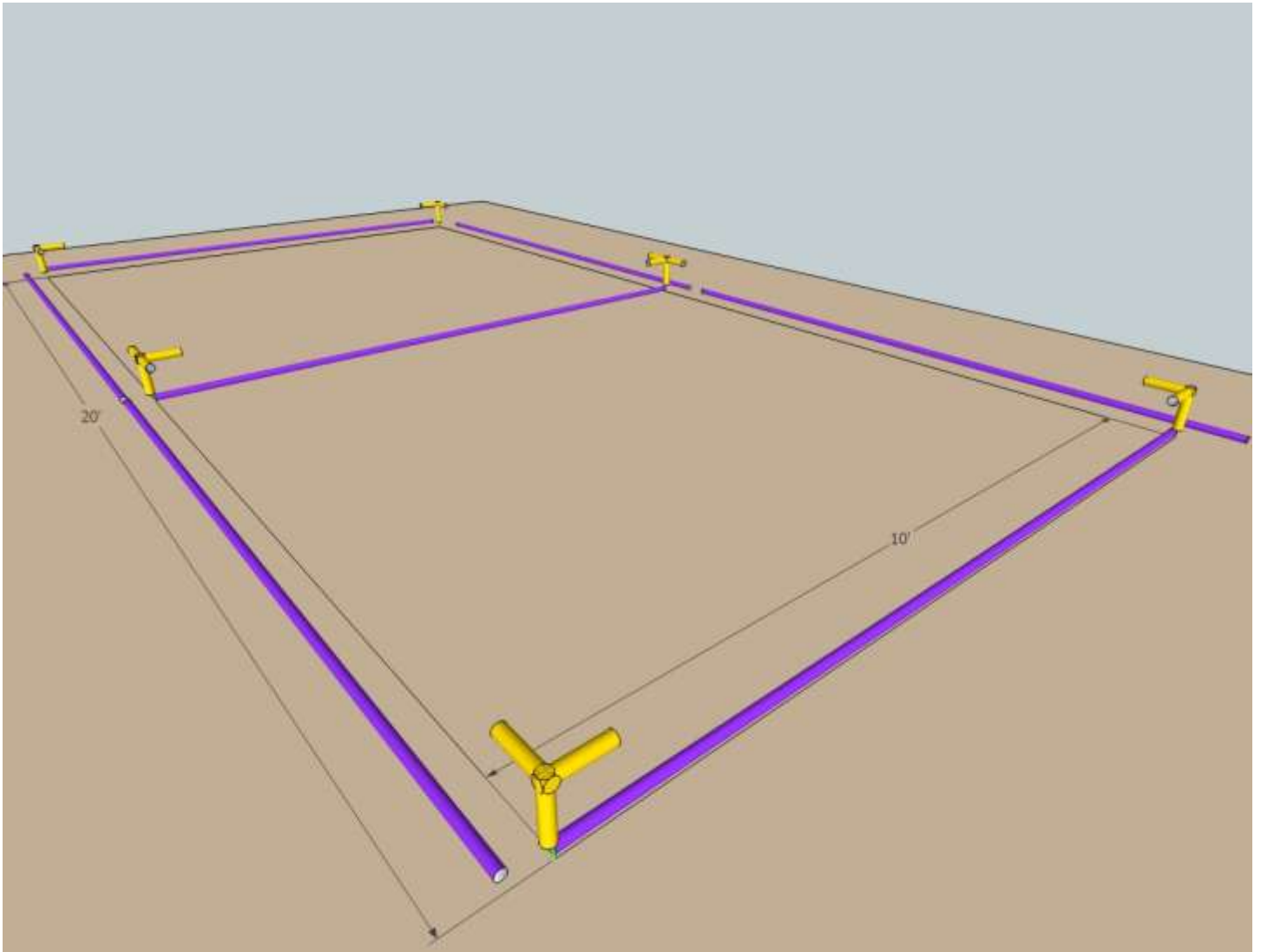

Lay out all the tubing. Make sure your measurements look close. Remember, 4 inches of the pipe go INSIDE the connectors.

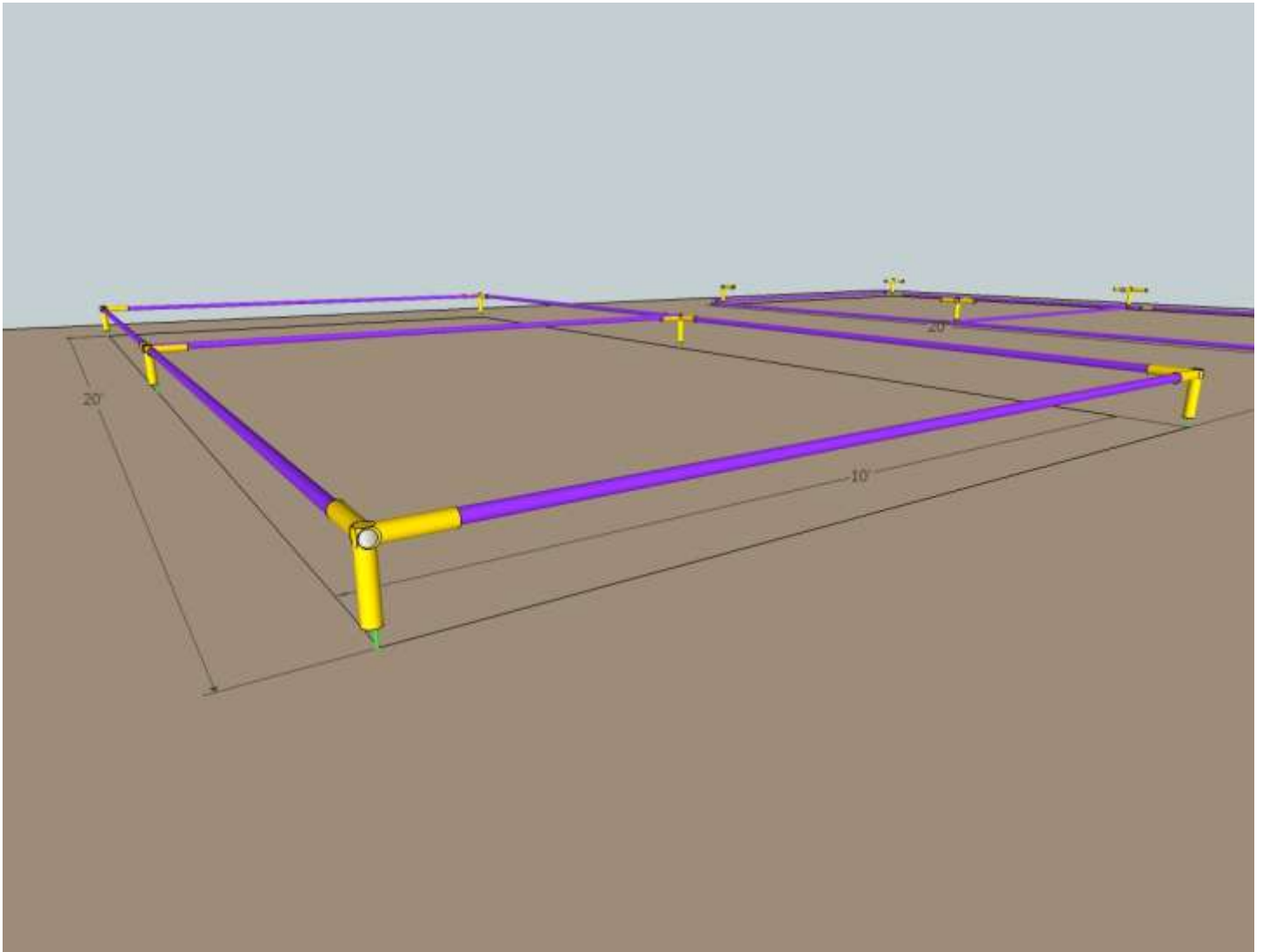

With a little bit of wiggling, you should be able to build your frame with the Connectors sitting on top of the rebar stakes. If you have to move the rebar to “make it work” it is a lot easier to do that now, than when you have the thing up in the air.

A word on how to tighten these things; we used a short screwdriver, and tighten until the felt “snug.” The connectors will not “STOP SOLID” no matter how hard you tighten them. Strong arming the connector will bend the tubing, preventing you from disconnecting on teardown.

If you have any doubts on tightness, Hold the screwdriver with three fingers and tighten until you can’t move it easily. This is the right amount.

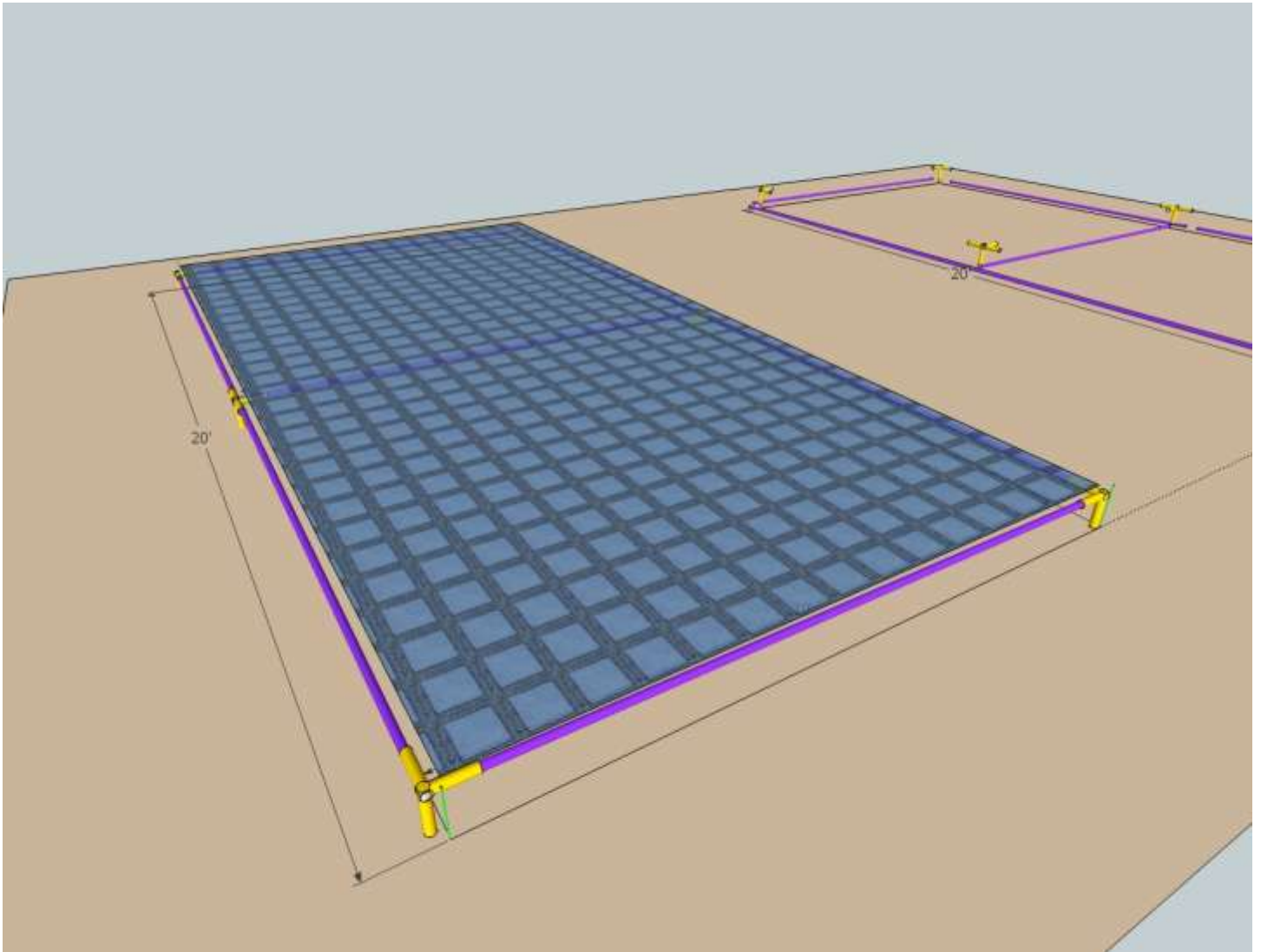

IF you have NO WIND, you can go ahead and put the tarp on the frame with bungee balls. This will make things a lot easier down the road. No standing on tip toes, etc.

DO NOT RAISE A FRAME WITH THE TARP ON IN THE WIND!

This will, at best, bend the frame and you leave you with a nice pretzel art piece. This is a big sail, so unless you want to chase your frame down the Playa, or help whomever it hits, or buy a new rental car windshield, ...

REALLY.... Seriously, dangerous in the wind.

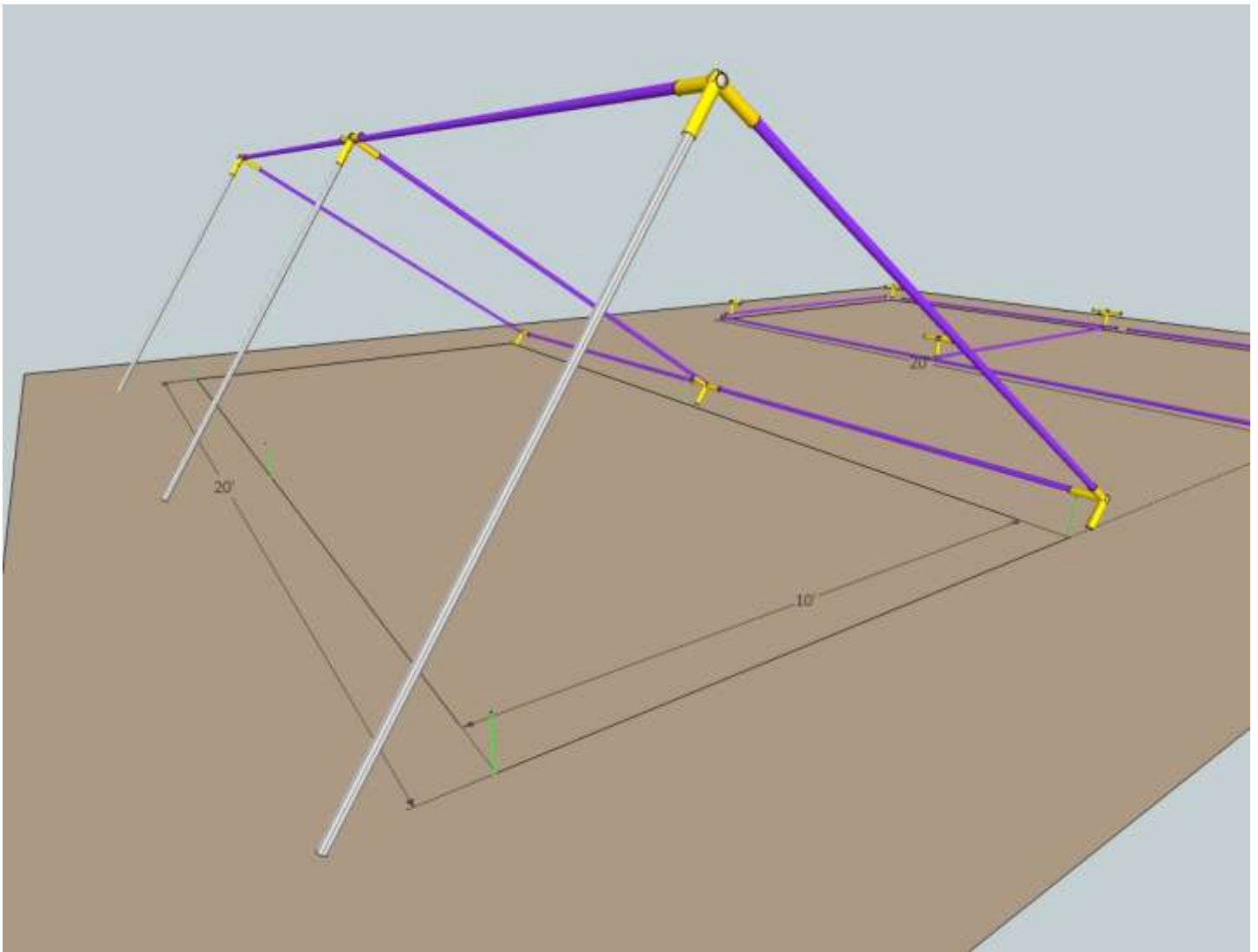

So HOW DO YOU RASIE IT IN THE WIND?

Leave the tarp in the car until we get everything ready. If you don't like taking chances, then have two people to help you. Each of you will have a pole in one hand, and grab the frame with the other.

Lift the frame about "Half Way" up. Slip the tubing into the connector.

Raise it until the connector slides in all the way and tighten it down.

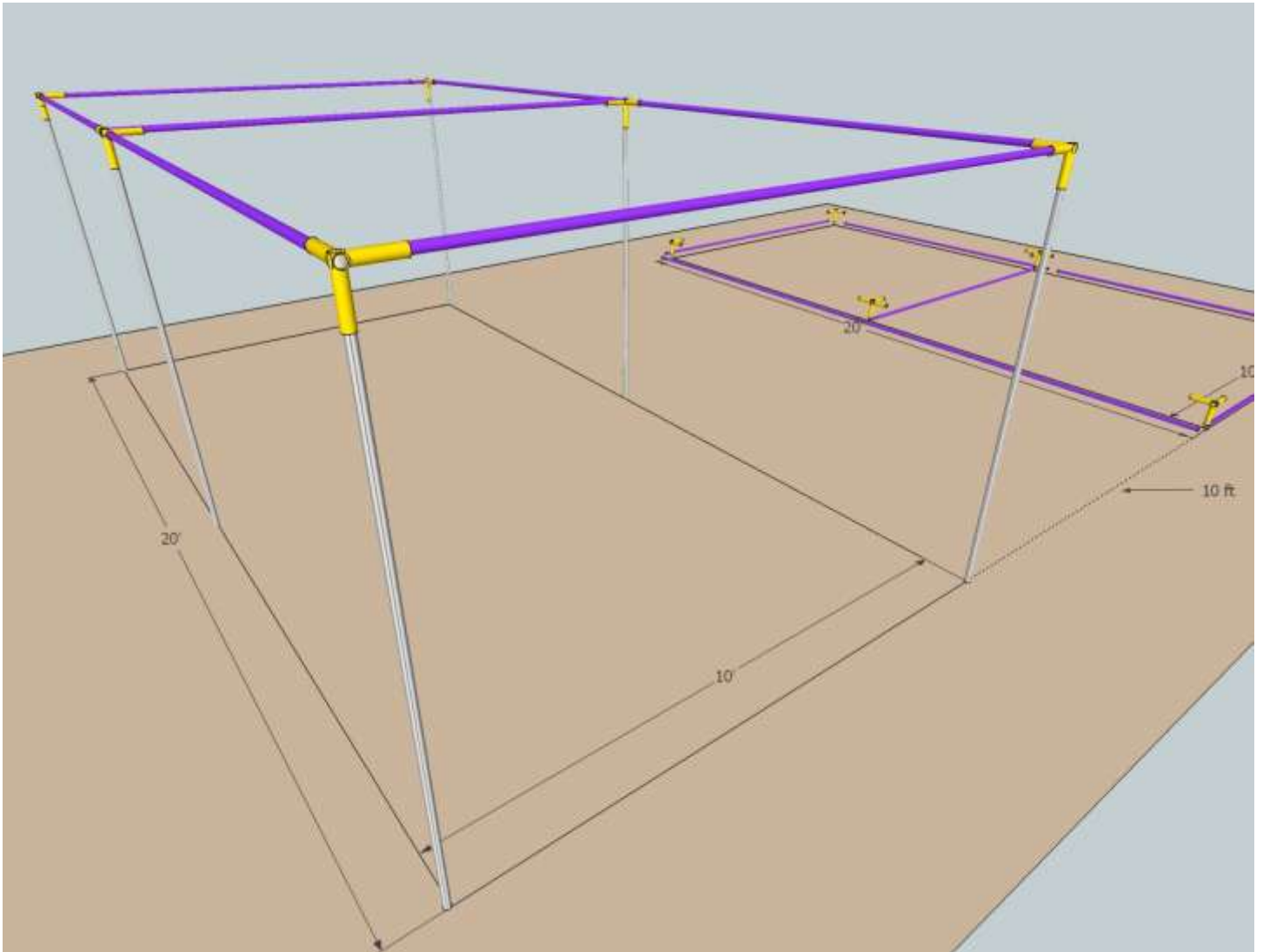

Repeat with the other side. The frame and poles will wiggle a lot. Don't worry, the once everything is tight and in place, it will be fine.

Once you have the frame up, Lift each corner and place over the rebar stake. Re-adjust if you need to, just keep that Golden Spike in place! Next we will secure to the ground.

DO NOT LEAVE UNTIL THE REBAR IS DONE . . . and unexpected wind gust will tear it apart.

The design is not strong until it is rebarred.

This pic is a view of a dust storm in the middle of the day. Yes, the sun is blotted out by the dust. It really was that dark!

Notice dust blasting those tents under a "regular" style of shade. You can sip your mint julep in the comfort of your wind protected pod and laugh as they hide.

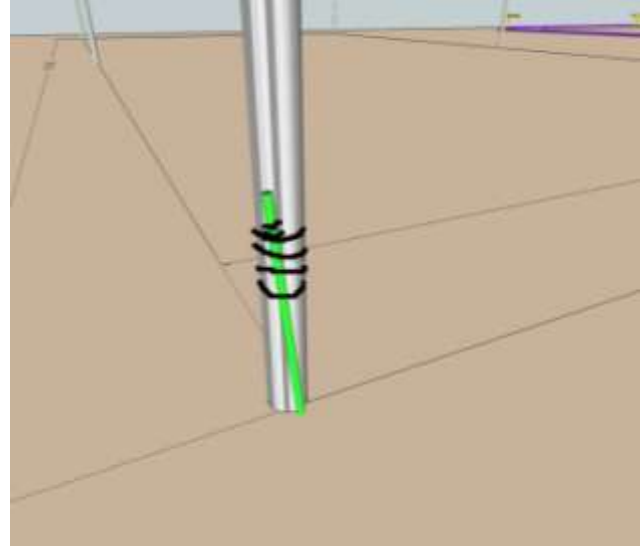

Figure 5: Dust storm at Midday.

The art and ZEN of Rebar

Securing a structure with rebar is a fine art. U shaped, extra long, double Cross Over, Tape and Wire, wing and a prayer; these fine techniques have been debated for years. In this tutorial we will be using the Tape and Wire method. Simple to execute, easily removed but very strong.

Here is the basic technique:



Drive the 2 foot rebar at a slight angle next to the base of the pole.
Leave 6-8 inches above ground.

Wrap the Rebar "TIE WIRE" around the end of the rebar, then around the pole several times. Just hands tighten. You will be "frapping" it on the next step.

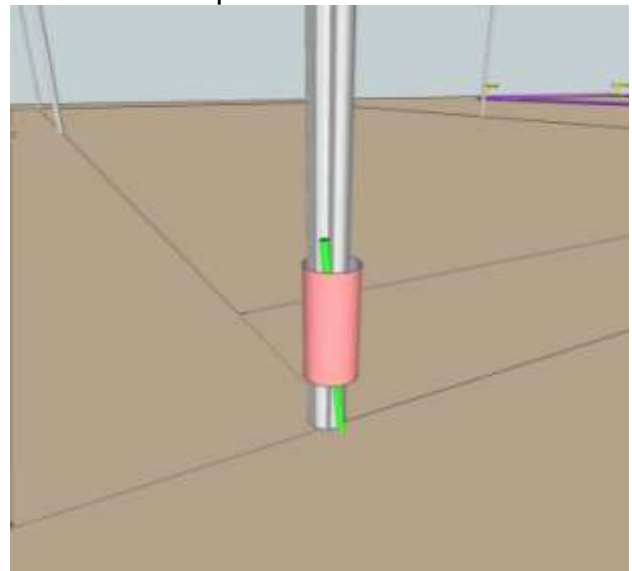
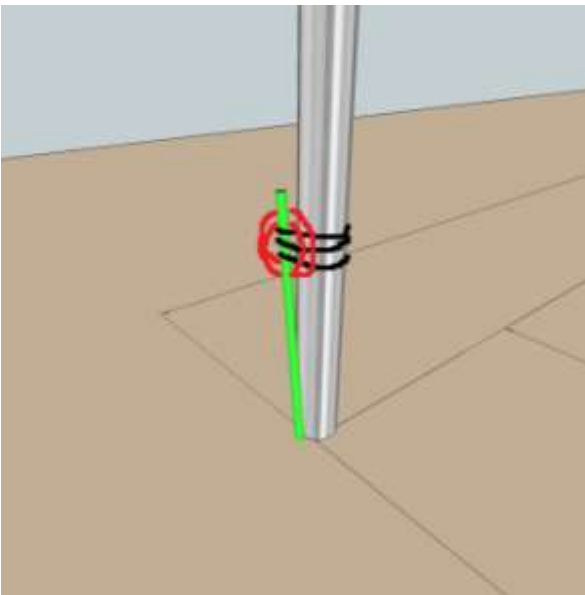

FRAP the wire. This tightens the first coils by squeezing them together.
Frapping is done with a pair of pliers.

Cover the whole thing with Duct Tape.
This will prevent wire from snagging your costume or cutting your leg.

Now that the frame is secured, **TAKE A BREAK! DRINK SOME WATER!**

Now comes the “Fun” stuff; it’s **TARP TIME...**

With all the dire warnings on previous pages, you may wonder “have they lost their mind?” Perhaps, but it is perfectly fine to raise a tarp in the wind. Sailors have done it for years 100 feet above the ocean in blinding storms, so why can’t we?

The trick to raising a tarp in the wind is the 2x4 – rebar trick. You use a 2x4 as the “hold down” and rebar it into the ground. This very simple method prevent grommets from ripping out, and forces the wind up over the shade, and keeping the dust out!

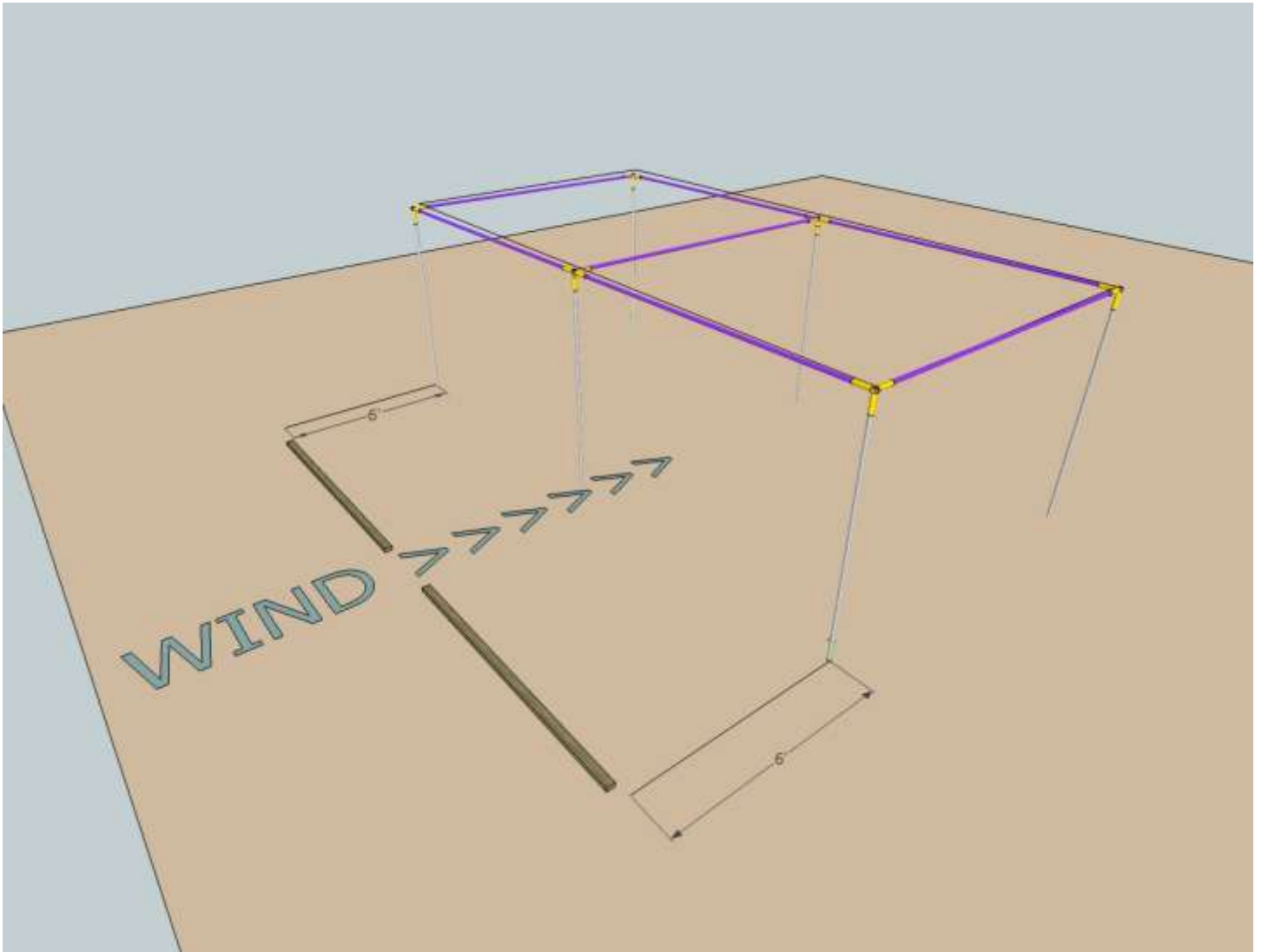

Place two 2x4's on the ground about 6 feet from the frame.

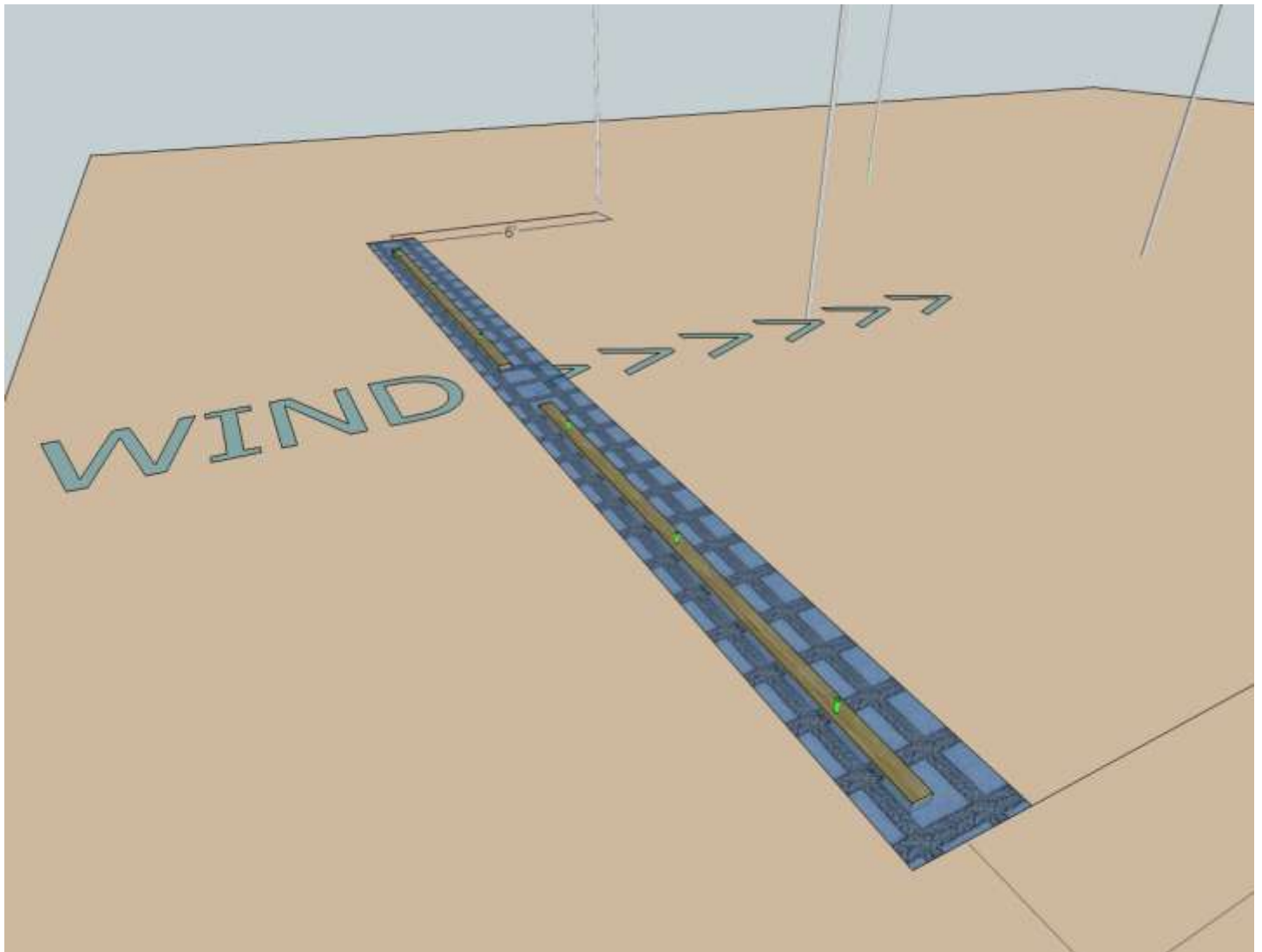

Keeping the tarp tightly folded, Use your drill to start holes along the 2x4. Drive your rebar in ALL THEY WAY> This will pin the tarp between the ground and the 2x4. If it is seriously windy, you may need to wrap the edge around the 2x4 for extra strength.

You will need to pile your cooler, friends or other heavy objects on the tarp while you are securing it to the ground or it will flap, tear and be generally annoying.

In the picture to the right, we had laid the tarp on the ground first, it was too windy to stay rolled up. We also tied ropes to the grommets on the loose end, so you could use them to “wrestle” the tarp into position.



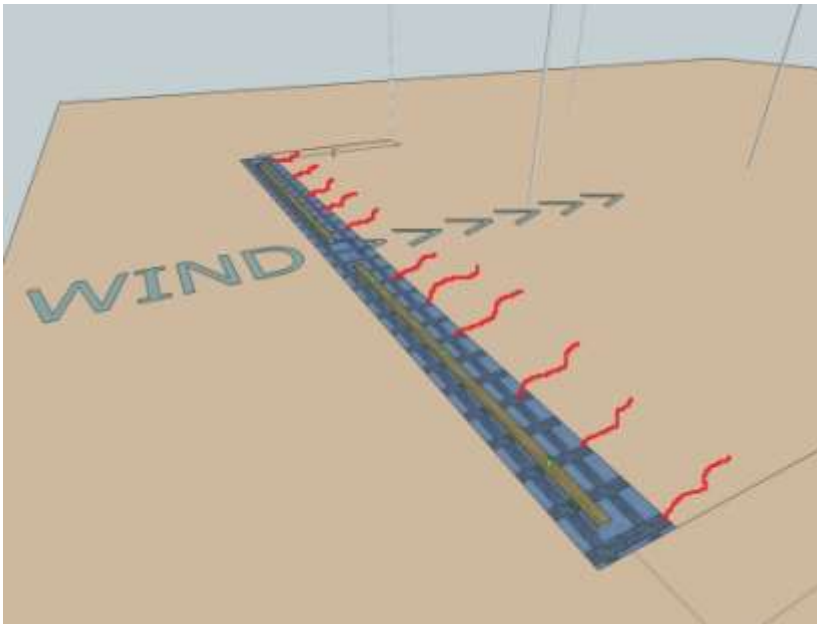

The ropes on the trailing grommets will help you control the flapping.

When we raised it up, we had several people slowly “back into” the flapping tarp.

Then they stood up, and the wind pushed against the tarp, and them. This held the tarp still while we tightened the ropes.

The biggest advantage of this is the wind break it creates. Once you have the tarp secured on the frame with ropes and ZIP TIES, we doubled them up, the team walks inward and enjoys the calm behind the tarp.

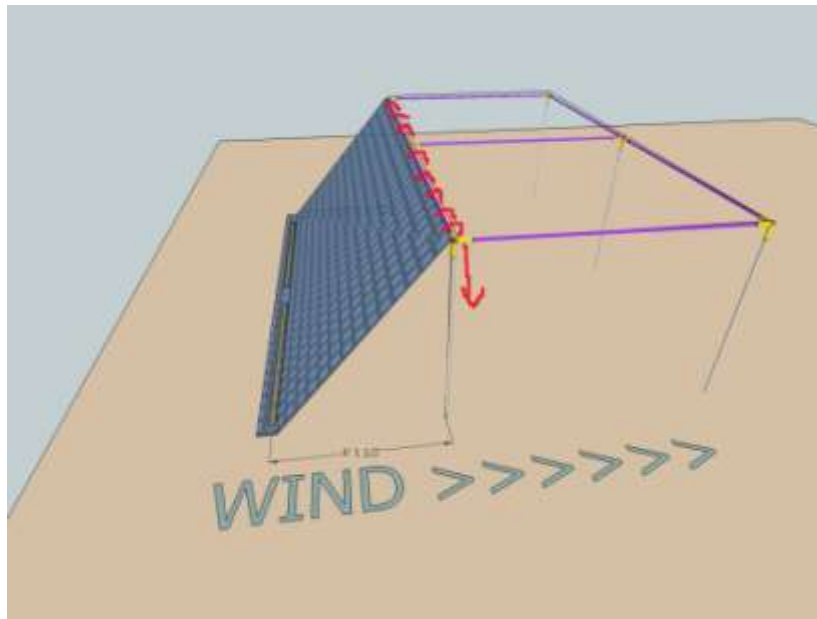

In the LEE of the windbreak, you can attach the Roof Tarp, then do the same thing! One bungee ball at a time, you slowly unroll the tarp and connect to the overhead frame.

Once this is done, You can begin building the second frame and start the process to finishing up!

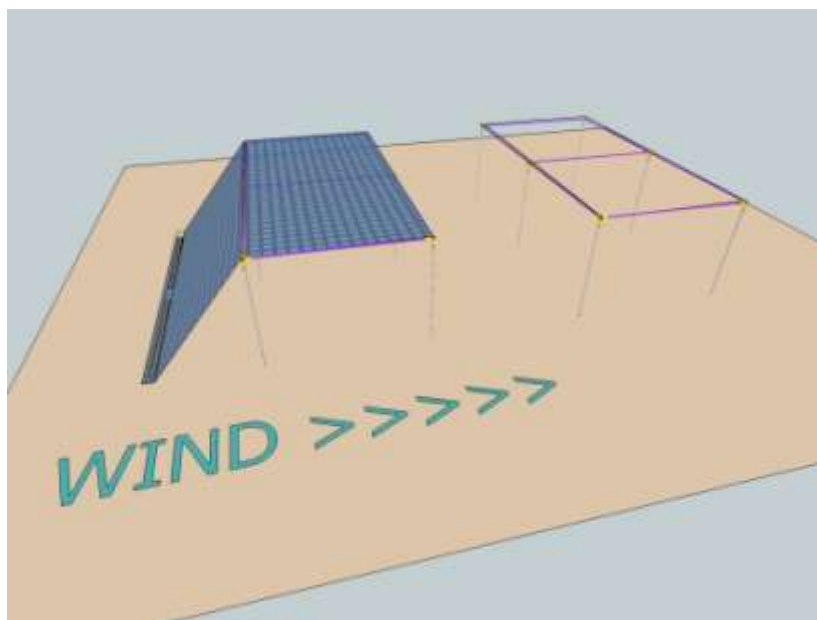

Some hardy souls just put all the framing up at once, then skin them. That’s up to you!

In calm conditions of light winds, two people can easily handle the tarps. Anything stronger than that it’s “ALL HANDS ON DECK.”

You will need AT LEAST 6-8 people to put the tarps on in heavy wind; less than that risks injury or damaging your gear.

As you finish the second frame, connect the two frames together and lace the middle tarp first. This will increase your windbreak, and you can work safely. Once you have the angle tarps secured on the back and or sides you are ready to move in!

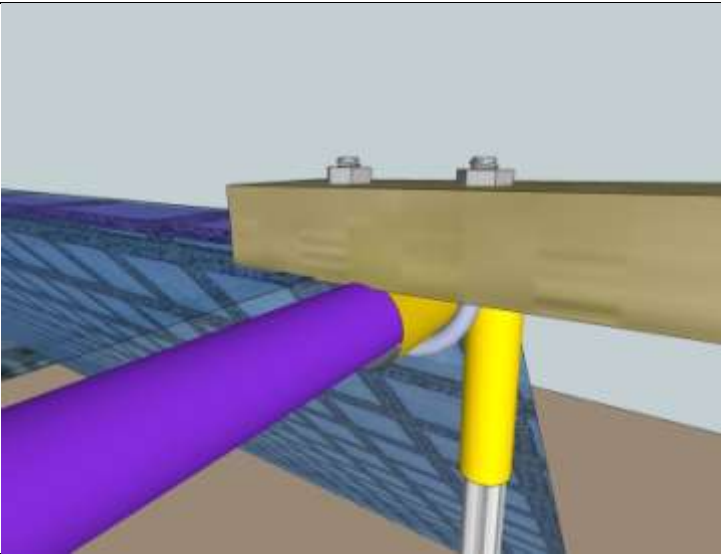

Connect the two frames together with three 2x4x10 ft boards. The simplest method to connect is to pre-drill two holes for a U-bolt.

Secure at the connector. If you place in the middle of a tube, it could bend.

These CAN shift around in the storm, so check them occasionally for loosening.

Some folks use wing nuts on the U-bolt to ease construction.

